

K4 SERIES GREENTEC
NEW!
ENGINE

Brand, Model	Perkins, 904J-E36TA
Number of cylinders	4
Max. Power	74,3 HP (55,4 kW) @2200 rpm
Max. Torque	424 Nm @1200 rpm
Displacement	3,621 cc
Bore & Stroke	ø 98 x 120 mm
Emission Class	EU:Stage 5, US: Tier 4 final

High power and torque output, water cooled turbocharged diesel engine.

AXLES

- Heavy duty service type axles
- Planetary outboard type reduction
- Total 16 degrees oscillation on the front axle
- Torque proportional type front axle differential
- LSD (Limited Slip Differential) type rear axle differential
- Locking type rear axle differential (optional)

CAB&HOOD

- Widened visual angle
- Ergonomic & Aesthetic Interior Design
- High capacity A/C system (option)
- Improved ventilating with 17 air nozzles
- Cool-box (with A/C system)
- ROPS and FOPS certificated cab
- 4.3" TFT display on front and on rear side panel
- Pool type floor mats
- Mechanical lever control
- Seat Mounted Controls improve Operator Comfort & Ergonomics (with joysticks model)
- Seat entegreted radio control button (with joysticks model)
- TIPSHIFT (FNR) function
- RTD (Return to dig)
- Multi purpose bucket with proposal control
- Autotilt steering wheel
- Loader boom lock
- Double brake systsem
- Storage boxes
- Foldable side steps
- Phone and cup holder
- Interior led lights
- MP3 radio
- Bluetooth radio (option)
- USB charging ports
- Openable cooling package
- Smartlink (option)

HYDRAULIC SYSTEM

Simple, reliable and high efficient tandem gear pump	
Main pump flow	90 L/min @2200 rpm
Pressure	227 bar
Auxiliary pump flow	57,2 L/min @2200 rpm
Pressure	170 bar
Closed type hydraulic system with variable displacement piston type pump, renewable flowsharing and valves with regeneration (Optional)	
Main pump flow	163 l/min
Pressure	255 bar

DRIVING SPEED

1 st gear	4	km/h
2 nd gear	7	km/h
3 rd gear	9	km/h
4 th gear	15	km/h
5 th gear	24	km/h
6 th gear	40	km/h

TRANSMISSION

- Autoshift transmission for heavy duty service
- Torque converter with 2,38:1 stall ratio
- Electrically controlled 2 Wheel drive or 4 Wheel Drive selection
- 6 forward, 3 reverse gears (Lock-Up is option)
- Transmission oil cooler
- A neutral circuit allows starting only when the control lever is in neutral position for safety.

TIRES

Front	16/70 - 20 12 Ply Rating
Rear	16,9 - 28 14 Ply Rating (Optional : 18,4- 26 12 Ply Rating)

FILLING CAPACITIES

Engine oil pump	10	L
Engine cooling system	16	L
Fuel Tank	140	L
Hydarulic oil tank	70	L
Transmission oil	16	L

OPERATING WEIGHT

Operating weight with standard equipment : 8950 kg

Operational weight, complying with the ISO 6016 standards, includes full fuel tank, hydraulic system and other liquids, 75 kg operator weight and standard equipped machine weight. Optional equipments are not included.

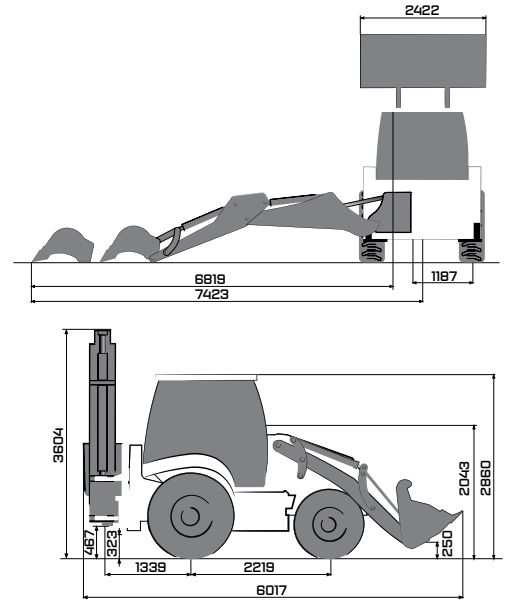
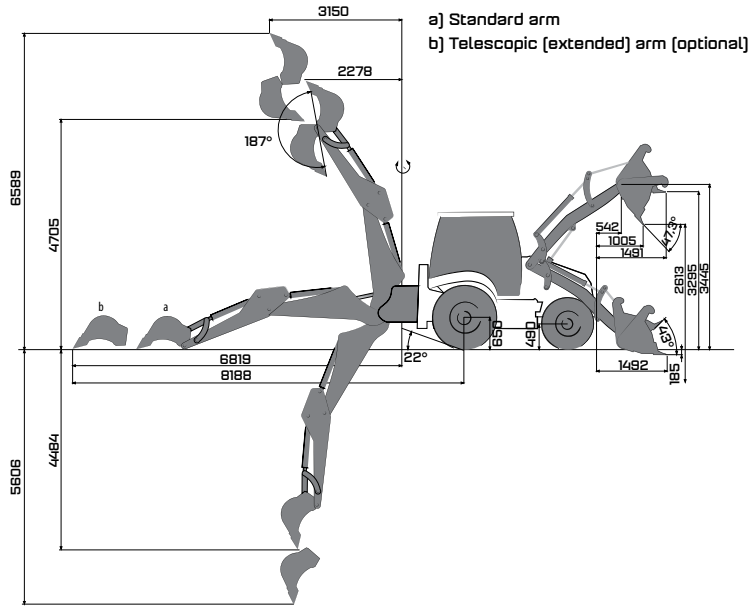



LOADER PERFORMANCE

	Open Type hydraulic Sys.	Close Type hydraulic Sys.
6 in 1 bucket capacity	1.0 m ³	
Max. bucket breakout force	7230 kgf	7380 kgf
Max. loading arm breakout force	6460 kgf	7380 kgf
Lifting capacity to max. height	3140 kg	3660 kg







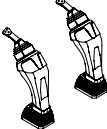
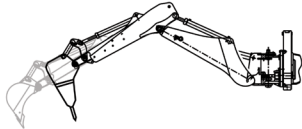
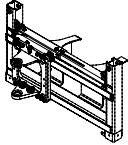





BACKHOE PERFORMANCE

	Standard arm		Telescopic arm extended		Telescopic arm retracted	
	Open Type sys.	Close Type sys.	Open Type sys.	Close Type sys.	Open Type sys.	Close Type sys.
Bucket capacity	0.18 m ³					
Max. bucket breakout force	6111 kgf	6865 kgf	6252 kgf	7020 kgf	6252 kgf	7020 kgf
Max. arm breakout force	2928 kgf	3290 kgf	1986 kgf	2230 kgf	2814 kgf	3160 kgf

OPTIONAL ACCESSORIES

			
Air conditioner	MSS (Motion Stabilizer System)	Seat mounted joystick	Hydraulic breaker inst. + Telescopic arm
			
Powerslide			

OPTIONAL ATTACHMENTS

					
Snow blade	Timber grab	General purpose bucket	Trapezoidal ditch bucket	Ripper	Tilting bucket
					
Clamshell grab	Backhoe bucket of different sizes	Hydraulic breaker	Auger	Fork arms with quick coupler	Fork arms, for quick couple mechanism