

NEW!

ENGINE

Model	: ISUZU-4HK1X
Type	: Water-cooled, 4 cycle, 4 cylinders, line type direct injection, turbocharger, intercooler, electronic diesel engine
Power	: 172 HP (128 kW) @2000 rpm / SAE J1995 (Gross)
Max. Torque	: 670 Nm @1600 rpm (Gross)
Displacement	: 5193 cc
Bore and Stroke	: 115 mm x 125 mm
Emission Class	: Stage V-EU

UNDERCARRIAGE

X Type Lower Frame Construction Pentagon Box Type Chassis

Shoe	: Triple grouser
No. Of Shoes	: 2 x 49
No. Of Lower Rollers	: 2 x 9
No. Of Upper Rollers	: 2 x 2
Track Tensioning	: Hydraulic Spring Tensioning

CAB

- Improved operator's all round visibility
- Increased cabin internal space
- Use of six viscomount cabin mountings that dampen the vibrations
- High capacity A/C
- High resolution, led backlight, color LCD display
- Opera Control System
- Cooled storage room
- Glass holder, book and object storage pockets
- Pool type floor mat
- Improved operator's comfort through versatile adjustable seat
- Ergonomically redesigned cabin through relocated switch board, and re-styled travel pedals and joysticks.

SWING SYSTEM

Swing Motor	: Axial piston type integrated with shock absorber valves
Reduction	: 2 stage planetary gear box.
Swing Brakes	: Hydraulic multi disc type, automatic warnings
Swing Speed	: 12,60 rpm

TRAVEL AND BRAKERS

Travel	: Fully hydrostatic
Travel Motors	: Axial piston type
Reduction	: 2 stage planetary gear
Travel Speed	
High Speed	: 5,8 km/h
Low Speed	: 3,8 km/h
Max. Drawbar Pull	: 18.310 kgf
Gradeability	: 35° (%70)
Parking Brake	: Hydraulic multi disc type
Ground Pressure (600mm Shoe)	: 0,50 kgf/cm ²

HYDRAULIC SYSTEM

Main Pump	
Type	: Double variable displacement axial piston pumps
Max. Flow	: 2 x 233 L/min
Pilot Pump	: Gear, 20 L/min
Relief Valves	
Attachment	: 350 kgf/cm ²
Power Boost	: 370 kgf/cm ²
Travel	: 350 kgf/cm ²
Swing	: 306 kgf/cm ²
Pilot	: 40 kgf/cm ²
Cylinders	
Main Boom	: 2 x ø 120 x ø 85 x 1.300 mm
Stick Cylinder	: 1 x ø 135 x ø 95 x 1.520 mm
Bucket Cylinder	: 1 x ø 95 x ø 70 x 910 mm

OPERA CONTROL SYSTEM

- Easy-to-use control panel and menu
- Improved fuel economy and productivity
- Maximum efficiency by selection of power and work modes
- Overheat prevention and protection system without interrupting the work
- Automatic powerboost switch-on and switch-off
- Automatic electric power-off
- Maintenance information and warning system
- Error mode registry and warning system
- Ability to adjust hydraulic flow from Opera screen
- Maintenance information and warning system
- Automatic powershift to improve performance
- Selection of multi-language on control panel.
- Real time monitoring of operational parameters such as pressure, temperature, engine load
- Anti-theft system with personal code
- Possibility to register 27 different operating hours
- Rear-view, arm-view camera (Optional)
- HIDROMEK Smartlink (Optional)

CAPACITY

Fuel Tank	: 405 L	Radiator	: 33 L
Hydraulic Tank	: 152 L	Engine Oil	: 23 L
Hydraulic System	: 285 L	Urea tank	: 16 L

ELECTRICAL SYSTEM

Voltage	: 24V
Battery	: 2 x 12 V / 150 Ah
Alternator	: 24V / 50 A
Starting Motor	: 24V / 5 kW

LUBRICATION

Centralized lubrication system is provided for lubrication all difficult-to-reach parts on the components, such as boom and arm

OPERATING WEIGHT

Standard machine operating weight : 25.650 kg

Operational weight, complying with the ISO 6016 standards, includes full fuel tank, hydraulic system and other liquids, 75kg operator weight and standard equipped machine weight. Optional equipments are not included.

HMK 230 LCLR H4

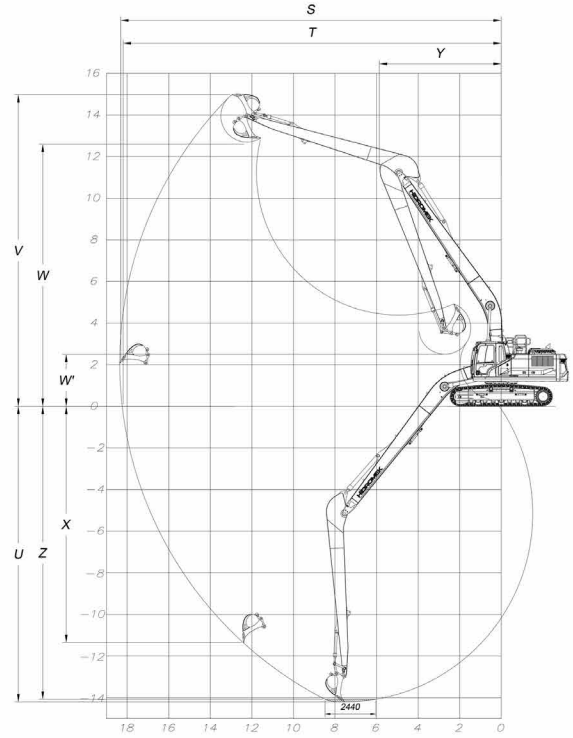
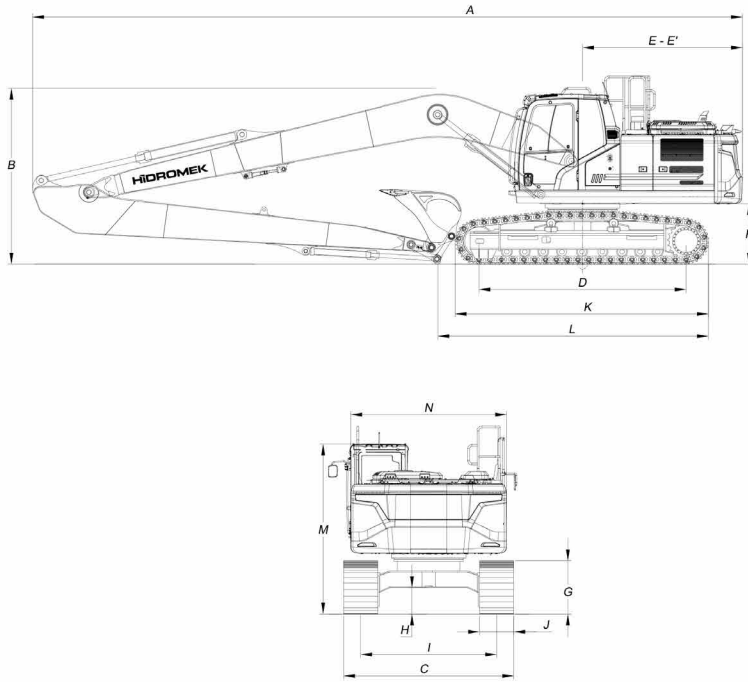

GENERAL DIMENSIONS

Boom Dimension	8.500 mm
Arm Dimension	6.100 mm
A - Overall Length	12.440 mm
B - Boom (Shipping) Height	3.090 mm
C - Lower Frame Width	3.090 mm
D - Track Base Length	3.640 mm
E - Counterweight Distance	2.810 mm
E' - Counterweight Turning Radius	2.830 mm
F - Upper Chassis to Ground Clearance	1.065 mm
G - Crawler Height	935 mm
H - Ground Clearance	465 mm
I - Track Gauge	2.390 mm
J - Shoe Width	700 mm
K - Lower Chassis Length (from shoe)	4.460 mm
L - Shipping Length	4.780 mm
M - Cab Height	3.010 mm
N - Upper Frame Width	2.740 mm

* Standard

WORKING DIMENSIONS

Boom Dimension	8.500 mm
Arm Dimension	6.100 mm
S - Maximum Reach Distance	15.070 mm
T - Maximum Reach at Ground Level	14.960 mm
U - Maximum Digging Depth	11.450 mm
V - Maximum Digging Height	13.120 mm
W - Maximum Unloading Height	10.710 mm
W' - Minimum Unloading Height	2.320 mm
X - Maximum Vertical Wall Digging Depth	10.930 mm
Y - Minimum Swing Radius	4.290 mm
Z - Maximum Digging Depth (2440 mm level)	11.320 mm

DIGGING PERFORMANCE

Standard Bucket Capacity (SAE)	0,50 m ³
Bucket Digging Force (Power Boost) ISO	6.600 kgf
Arm Crowd Force (Power Boost) ISO	4.200 kgf



HIDROMEK®

FACTORY - HEAD OFFICE

Ahi Evran OSB Mahallesi Osmanlı Caddesi No:1 06935 Sincan / ANKARA / TURKEY
Tel: (+90) 312 267 12 60 Fax: (+90) 312 267 12 39
www.hidromek.com

Notice:
Hidromek has the right to modify the specifications and design of the model indicated on this brochure without prior notice.