

NEW!

ENGINE

Model	: ISUZU-6HK1X
Type	: Water-cooled, 4 cycle, 6 cylinders, line type direct injection, turbocharger, intercooler, electronic diesel engine
Power	: 284 HP (212 kW) @2000 rpm / SAE J1995 (Gross) : 268 HP (200 kW) @2000 rpm / SAE J1349 (Net)
Max. Torque	: 1080 Nm @1500 rpm (Gross) : 1070 Nm @1500 rpm (Net)
Displacement	: 7790 cc
Bore and Stroke	: ø 115 mm x 125 mm
Emission Class	: R96 (GB3)

UNDERCARRIAGE

X Type Lower Frame Construction Pentagon Box Type Chassis	
Shoe	: Triple grouser
No. Of Shoes	: 2 x 48
No. Of Lower Rollers	: 2 x 8
No. Of Upper Rollers	: 2 x 2
Full Trackguard	: Complete
Track Tensioning	: Hydraulic Spring Tensioning

CAB

<ul style="list-style-type: none"> • Improved operator's all round visibility • Increased cabin internal space • Use of six viscomount cabin mountings that dampen the vibrations • High capacity A/C • High resolution, led backlight, color LCD display • Opera Control System • Cooled storage room • Glass holder, book and object storage pockets • Pool type floor mat • Improved operator's comfort through versatile adjustable seat • Ergonomically redesigned cabin through relocated switch board, and re-styled travel pedals and joysticks.

TRAVEL AND BRAKERS

Travel	: Fully hydrostatic
Travel Motors	: Axial piston type
Reduction	: 2 stage planetary gear
Travel Speed	
High Speed	: 4,9 km/h
Low Speed	: 2,9 km/h
Max. Drawbar Pull	: 30.725 kgf
Gradeability	: 35° (%70)
Parking Brake	: Hydraulic multi disc type
Ground pressure	: 0,73 kgf/cm ²

LUBRICATION

Centralized lubrication system is provided for lubrication all difficult-to-reach parts on the components, such as boom and arm

HYDRAULIC SYSTEM

Main Pump	
Type	: Double variable displacement axial piston pumps
Max. Flow	: 2 x 290 L/min
Pilot Pump	: Gear, 28,5 L/min
Relief Valves	
Attachment	: 350 kgf/cm ²
Travel	: 350 kgf/cm ²
Swing	: 285 kgf/cm ²
Pilot	: 40 kgf/cm ²
Cylinders	
Main Boom	: 2 x ø 145 x ø 100 x 1.510 mm
Stick Cylinder	: 1 x ø 170 x ø 120 x 1.735 mm
Bucket Cylinder	: 1 x ø 145 x ø 105 x 1.280 mm

OPERA CONTROL SYSTEM

<ul style="list-style-type: none"> • Easy-to-use control panel and menu • Improved fuel economy and productivity • Maximum efficiency by selection of power and work modes • Overheat prevention and protection system without interrupting the work • Ability to adjust hydraulic flow from Opera screen • Automatic electric power-off • Maintenance information and warning systek • Error mode registry and warning system 	<ul style="list-style-type: none"> • Maintenance information and warning system • Automatic powershift to improve performance • Selection of multi-language on control panel. • Real time monitoring of operational parameters such as pressure, temperature, engine load • Anti-theft system with personal code • Possibility to register 26 different operating hours • Rear-view, arm-view camera (Optional) • Hidromek Smartlink (Optional)
--	---

SWING SYSTEM

Swing Motor	: Axial piston type integrated with shock absorber valves
Reduction	: 2 stage planetary gear box.
Swing Brakes	: Hydraulic multi disc type, automatic warnings
Swing Speed	: 9,3 rpm

CAPACITY

Fuel Tank	: 565 L	Radiator	: 55 L
Hydraulic Tank	: 265 L	Engine Oil	: 36 L
Hydraulic System	: 470 L		

ELECTRICAL SYSTEM

Voltage	: 24 V
Battery	: 2 x 12 V / 150 Ah
Alternator	: 24 V / 50 A
Starting Motor	: 24 V / 5 kw

OPERATING WEIGHT

Standard machine operating weight	: 37.700 kg
Operational weight, complying with the ISO 6016 standards, includes full fuel tank, hydraulic system and other liquids, 75 kg operator weight and standard equipped machine weight. Optional equipments are not included.	

HMK 360LC H4

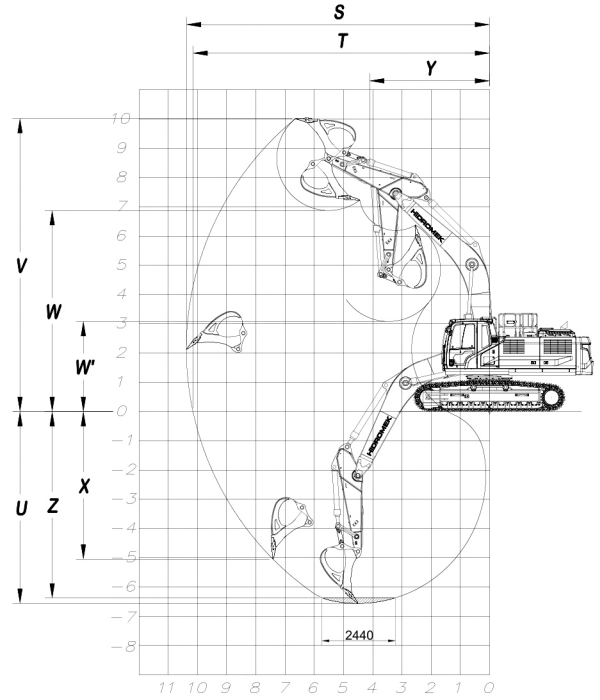
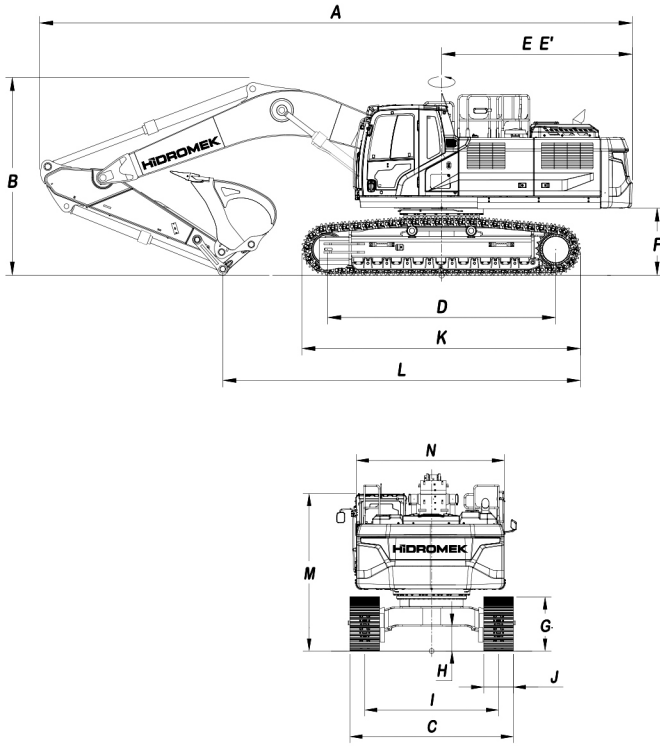

GENERAL DIMENSIONS

Boom Dimension	6.500 mm
Arm Dimension	*3.200 mm
A - Overall length	11.360 mm
B - Overall height of boom	3.610 mm
C - Overall Width	3.300 mm
D - Tumbler distance	4.030 mm
E - Rear end length	3.450 mm
E' - Tail swing radius	3.505 mm
F - Counterweight clearance	1.248 mm
G - Crawler height	1.100 mm
H - Minimum ground clearance	505 mm
I - Track gauge	2.700 mm
J - Shoe width	600 mm
K - Crawler length	4.980 mm
L - Length on ground	6.080 mm
M - Cab height	3.170 mm
N - Upperstructure width	3.990 mm

* Standard

WORKING DIMENSIONS

Boom Dimension	6.500 mm
Arm Dimension	*3.200 mm
S - Max. digging reach	11.340 mm
T - Max. digging reach on ground	11.130 mm
U - Max. digging depth	7.580 mm
V - Max. cutting height	10.610 mm
W - Max. dumping height	7.310 mm
W' - Min. dumping height	2.720 mm
X - Max. vertical wall digging depth	6.490 mm
Y - Min. front swing radius	4.460 mm
Z - Maximum Digging Depth (2440 mm level)	7.420 mm

DIGGING PERFORMANCE

Standard Bucket Capacity (SAE)	Light M. 2.1 m ³
Bucket digging force (power boost) ISO	23.200 kgf
Arm breakout force (power boost) ISO	16.900 kgf



HIDROMEK

FACTORY - HEAD OFFICE

Ahi Evran OSB Mahallesi Osmanlı Caddesi No:1 06935 Sincan / ANKARA / TÜRKİYE
Tel: (+90) 312 267 12 60 Fax: (+90) 312 267 12 39
www.hidromek.com

Notice:
Hidromek has the right to modify the specifications and design of the model indicated on this brochure without prior notice.