

**NEW!**

## ENGINE

Model	: ISUZU-AI-4HK1X
Type	: Water cooled diesel engine, 4 cycles, 4 cylinders, line-type, direct injection, turbocharger and intercooler
Power	: 172 HP (128 kW)@2000 rpm / SAE J1995 (Gross) : 162 HP (121 kW) @2000 rpm / SAE J1349 (Net)
Max. Torque	: 677 Nm @1500 rpm (Gross) : 656 Nm @1500 rpm (Net)
Displacement	: 5193 cc
Bore and Stroke	: 115 mm x 125 mm
Emission Class	: Stage IIIA / Tier 3 (EU/EPA)

## LOWER STRUCTURE (CHASSIS)

Chassis	: Box shaped, reinforced lower chassis, front dozer blade and rear outriggers (stabilizers) as standard figures.
Axles	: The pivot pin mounted front axle allows two options: 8° in each direction for best matching conditions, or could be locked at any desired position for perfect stability.
Tires	: 11,00 - 20 (16 pr)

## CAB

<ul style="list-style-type: none"> <li>• Improved operator's all round visibility</li> <li>• Increased cabin internal space</li> <li>• Use of six viscomount cabin mountings that dampen the vibrations</li> <li>• High capacity A/C</li> <li>• 8" touch TFT screen</li> <li>• Opera Control System</li> <li>• Cooled storage room</li> <li>• Glass holder, book and object storage pockets</li> <li>• Pool type floor mat</li> <li>• Improved operator's comfort through versatile adjustable seat</li> </ul>
--

## STEERING SYSTEM

The "orbital" type steering system controls a steering cylinder located on the front axle. Minimum turning radius is 6.800 mm.

## TRAVEL AND BRAKES

Travel	: Fully hydrostatic
Travel Motors	: Axial piston type
Reduction	: 2 stage planetary gear
Travel Speed	
High Speed	: 31 km/h
Low Speed	: 7,5 km/h
Max. Drawbar Pull	: 11.120 kgf
Gradeability	: 29° (%56)
Parking Brake	: Hydraulic, disc type with automatic warning
Service Brake	: Fully hydraulically operating disc type brakes with spring return, independent for front and rear axles.

## LUBRICATION

Centralized lubrication system is provided for lubrication all difficult-to-reach parts on the components, such as boom and arm

## HYDRAULIC SYSTEM

Main Pump	
Type	: 2 axial piston type pumps with double variable displacement and inclined plate
Max. Flow Rate	: 2 x 233 L/min
Pilot Pump	: Gear type, 20,5 L/min
Working Pressures	
Cylinders	: 350 kgf/cm <sup>2</sup>
Power Boost	: 370 kgf/cm <sup>2</sup>
Travel	: 370 kgf/cm <sup>2</sup>
Swing	: 306 kgf/cm <sup>2</sup>
Pilot	: 40 kgf/cm <sup>2</sup>
Cylinders	
Boom	: 2 x ø 120 x ø 85 x 1.300 mm
Arm	: 1 x ø 135 x ø 95 x 1.520 mm
Bucket	: 1 x ø 120 x ø 85 x 1.060 mm

## OPERA CONTROL SYSTEM

<ul style="list-style-type: none"> <li>• Easy-to-use control panel and menu</li> <li>• Improved fuel economy and productivity</li> <li>• Maximum efficiency by selection of power and work modes</li> <li>• Overheat prevention and protection system without interrupting the work</li> <li>• Automatic powerboost switch-on and switch-off</li> <li>• Automatic electric power-off</li> <li>• Maintenance information and warning system</li> <li>• Error mode registry and warning system</li> <li>• Ability to adjust hydraulic flow from Opera screen</li> </ul>	<ul style="list-style-type: none"> <li>• Maintenance information and warning system</li> <li>• Automatic powershift to improve performance</li> <li>• Selection of multi-language on control panel.</li> <li>• Real time monitoring of operational parameters such as pressure, temperature, engine load</li> <li>• Anti-theft system with personal code</li> <li>• Possibility to register 26 different operating hours</li> <li>• Rear-view, arm-view camera (Optional)</li> <li>• Hidromek Smartlink (Optional)</li> </ul>
---	---

## SWING SYSTEM

Swing Motor	: Axial piston type integrated with shock absorber valves
Reduction	: 2 stage planetary gear box.
Swing Brakes	: Hydraulic multi disc type.
Swing Speed	: 11,90 rpm

## FILLING CAPACITIES

Fuel Tank	: 345 L	Engine Oil	: 21 L
Hydraulic Tank	: 160 L	Engine Cooling Sys	: 33 L
Hydraulic System	: 318 L		

## ELECTRICAL SYSTEM

Voltage	: 24V
Battery	: 2 x 12V x 100 Ah
Alternator	: 24V / 50 A
Starting Motor	: 24V / 5 kW

## OPERATING WEIGHT

Standard machine operating weight	: 22.350 kg
-----------------------------------	-------------

Operational weight, complying with the ISO 6016 standards, includes full fuel tank, hydraulic system and other liquids, 75kg operator weight and standard equipped machine weight. Optional equipments are not included.

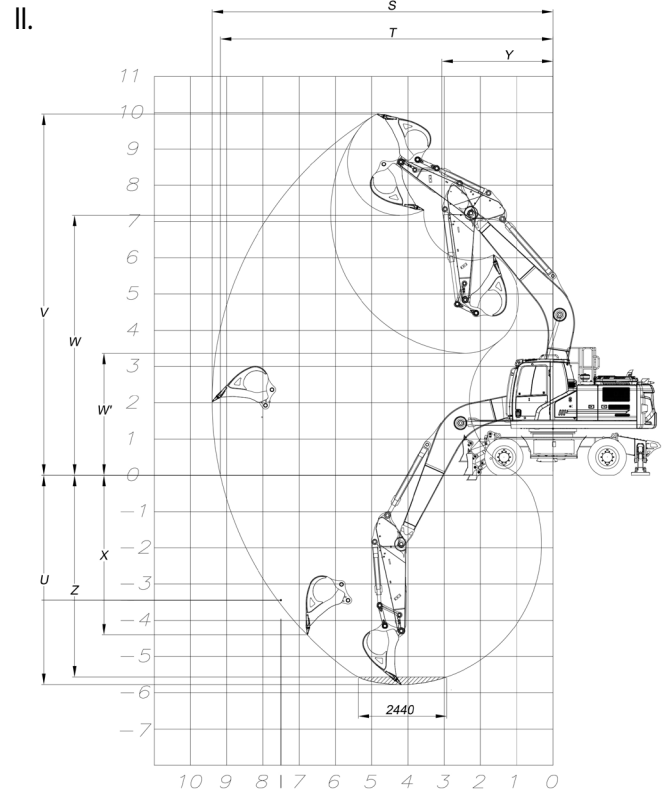
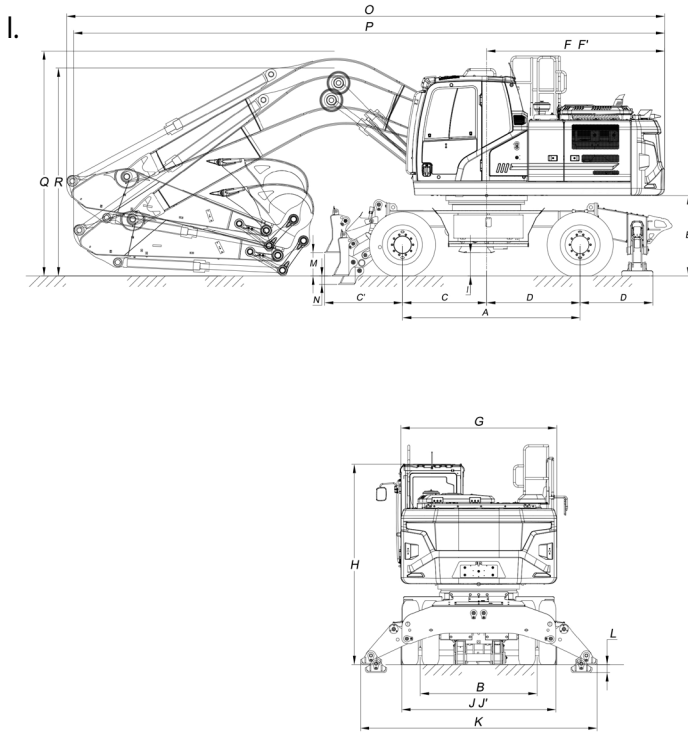

## I. GENERAL DIMENSIONS

Boom Dimension	5.600 mm	
Arm Dimension	*2.400 mm	2.920 mm
A Axle Distance	2.850 mm	
B Track Gauge	1.914 mm	
C Swing-centre to Front Axle	1.500 mm	
C' Front overhang	1.242 mm	
D Swing-centre to Rear Axle	1.350 mm	
D' Rear overhang	1.153 mm	
E Counterweight clearance	1.249 mm	
F Distance from center of swing to rear end	2.855 mm	
F' Tail Swing Radius	2.885 mm	
G Overall Width of upperstructure	2.500 mm	
H Overall height of cab	3.220 mm	
I Minimum Ground Clearance, Outrigger	348 mm	
I' Minimum Ground Clearance	384 mm	
J Overall Width tires	2.540 mm	
J' Overall width of Outrigger retract	2.550 mm	
K Overall Width Outrigger extend	3.791 mm	
L Max. Outrigger lower	117 mm	
M Dozer Blade Ground Clearance	353 mm	
N Max. Dozer Blade Lower	123 mm	
O Overall Length / Travel	9.590 mm	9.610 mm
P Overall Length/ Transport	9.480 mm	9.550 mm
Q Boom Height / Travel	3.610 mm	3.690 mm
R Boom Height / Transport	3.330 mm	3.450 mm

\* Standard

## II. WORKING DIMENSIONS

Boom Dimension	5.600 mm	
Arm Dimension	*2.400 mm	2.920 mm
S Maximum Digging Reach	9.400 mm	9.790 mm
T Maximum Digging Reach at Ground Level	9.170 mm	9.570 mm
U Maximum Digging Depth	5.770 mm	6.290 mm
V Maximum Digging Height	9.960 mm	10.020 mm
W Maximum Dumping Height	7.170 mm	7.280 mm
W' Minimum Dumping Height	3.360 mm	2.840 mm
X Maximum Vertical Digging Depth	4.430 mm	4.620 mm
Y Minimum Swing Radius	3.080 mm	3.050 mm
Z Maximum Digging Depth (2440 mm level)	5.560 mm	6.100 mm

\* Standard

## DIGGING PERFORMANCE

Standard Bucket Capacity (SAE)	0,9 m <sup>3</sup>
Bucket Digging Force (Power Boost) ISO	14.900 (15.800) kgf
Arm Crowd Force (Power Boost) ISO	11.800 (12.500) kgf