



ENGINE

Brand, Model	: KUBOTA
Type	: V2403-M-T-E3B Diesel Engine
Number of Cylinders	: 4 in line
Bore & Stroke	: 87 x 102,4 mm
Displacement	: 2434 cm ³
Maximum Power	: 59 HP (44 kW) @2700 rpm
Maximum Torque	: 165 Nm @1800 rpm
Emission Class	: Stage IIIA / Interim Tier 4 (EU/EPA)

High power and torque output, water cooled turbocharged diesel engine.

STANDARD EQUIPMENTS

- ROPS & FOPS Cab
- Air Conditioner
- Ergonomic Joystick Controls Integrated To Seat
- Multi Purpose Loader Bucket
- Loader Attachment Quick Hitch Mechanism
- Immobilizer
- Radio and MP3 Player
- Cylinders with Cushion
- Attachment Lock
- Hose Burst Valve
- Breaker Hydraulic Line
- Rotating Beacon
- Monolight Rear Window
- Openable Side Window
- Doom Light
- 12 Volt Socket
- Personal Storage Area
- Floor Mat
- Hand Throttle
- LCD Information Display
- Wide Visual Angle
- Battery Isolator
- Ease of service maintenance
- Reverse alarm



HYDRAULIC SYSTEM

Main Pump Flow	: 60 L/min @2700 rpm
Pressure	: 220 bar

DRIVE SYSTEM

- Servo controlled Axial Piston Variable Displacement Double Pumps driving Radial Piston, Multi-stroke hydraulic motors enabling forward and reverse motion.
- Service Brake is provided by Hydraulic Driving System
- Spring on, hydraulic pressure off park brake system
- Travel speeds 0-12 km/h forward and reverse.

CONTROLS

Ergonomic servo controlled joysticks mounted on the seat control driving and front loading operation. Same joysticks also control backhoe operation when the operator seat is turned to backhoe side.

TIRES

Front	: 10 x 16,5 10 Pr Skz
Rear	: 10 x 16,5 10 Pr Skz

OPERATING WEIGHT

Operating weight (with standard equipment) : 3.875 kg

Operational weight, complying with the ISO 6016 standards, includes full fuel tank, hydraulic system and other liquids, 75 kg operator weight and standard equipped machine weight. Optional equipments are not included.



HMK 62^{SS}

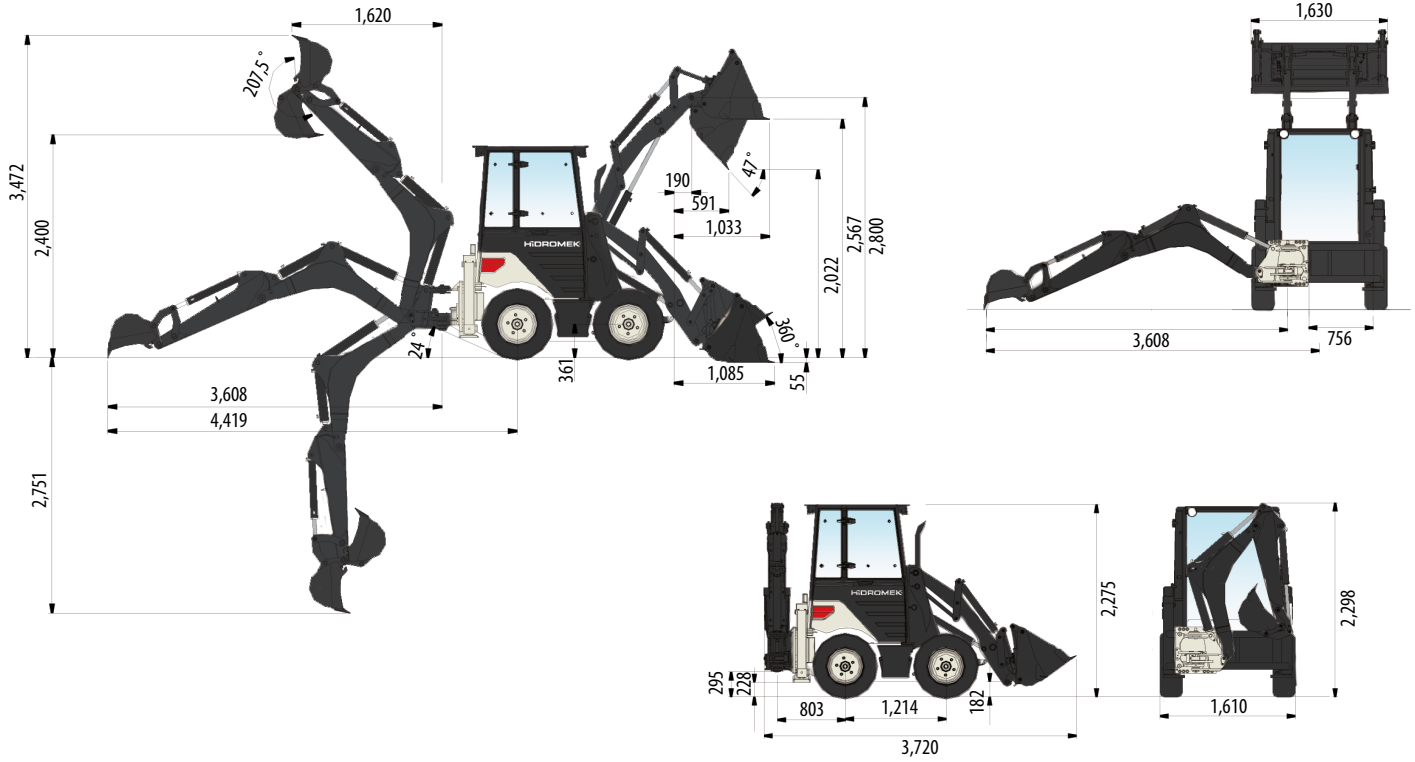

LOADER PERFORMANCE

4 in 1 bucket capacity	0,35 m ³
Max. bucket breakout force	2883 kgf
Max. loading arm breakout force	2600 kgf
Lifting capacity to maximum height	1370 kg

BACKHOE PERFORMANCE

Bucket capacity	0,06 m ³
Max. bucket breakout force	1985 kgf
Max. dipper breakout force	1500 kgf
Lifting capacity to maximum height (rear)	332 kg



Attachments



Hydraulic Breaker



Dozer Blades



Standard Bucket



Forks Mounted on Quick Coupler

HIDROMEK[®]

FACTORY - HEAD OFFICE

Ahi Evran OSB Mahallesi Osmanlı Caddesi No:1 06935 Sincan / ANKARA / TURKEY
Tel: (+90) 312 267 12 60 Fax: (+90) 312 267 12 39
www.hidromek.com

Notice:
Hidromek has the right to modify the specifications and design of the model indicated on this brochure without prior notice.