

H4 SERIES

HMK210W



HIDROMEK



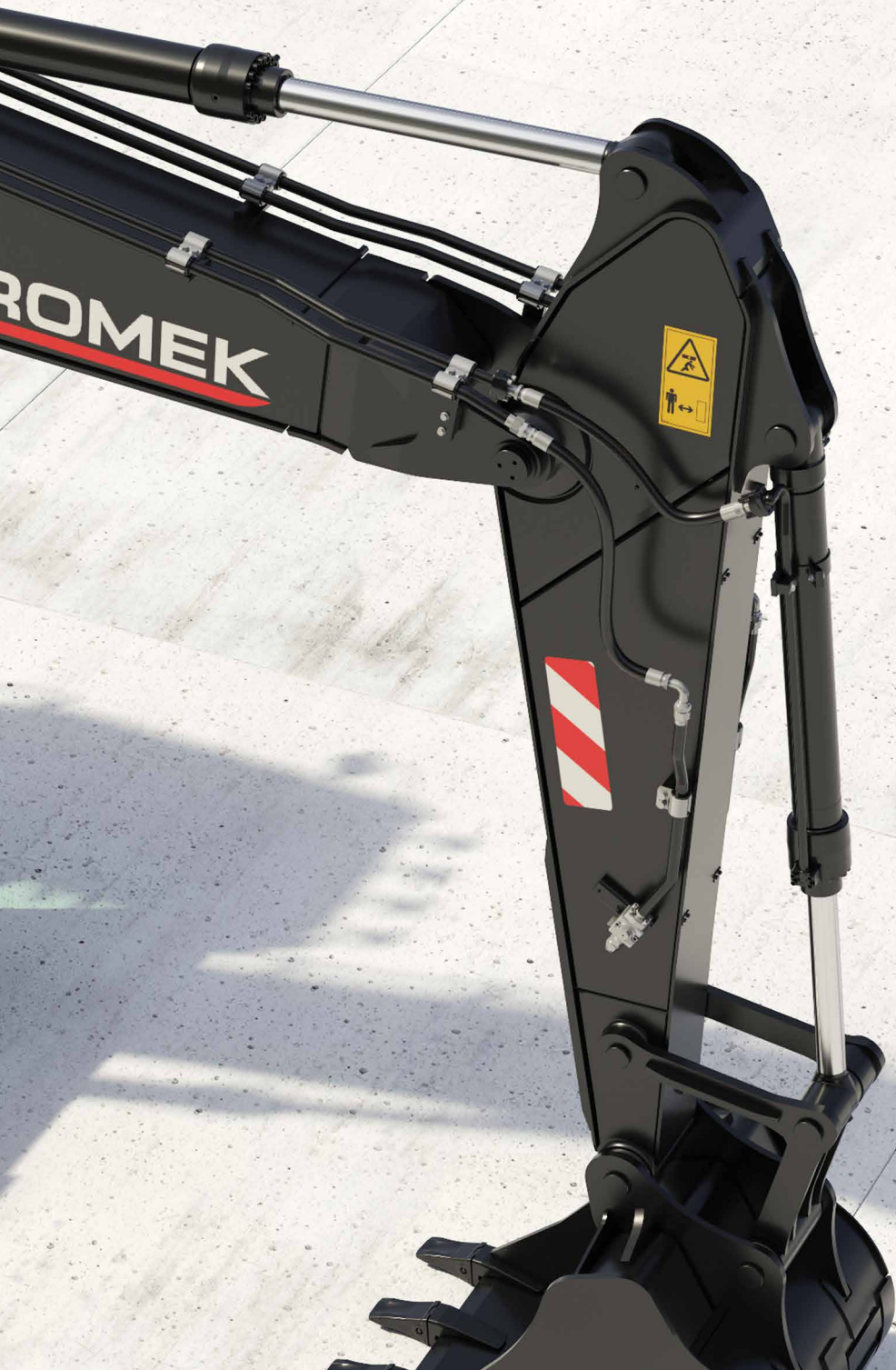

New H4 Series

Innovation coming from experience

Being produced with developed hydraulic system design, HiDROMEK's new H4 Series excavators offer an outstanding performance by working faster, more productively and more efficiently. H4 Series excavators produce more work with less fuel; hence, they are more profitable for their users than ever.

H4

SERIES



Performance.....6-7
Durability.....8-11
Safety.....12-13
Technology.....14-15
Comfort.....16-17
HIDROMEK Smartlink - Ease of Service.....18-19
Technical Features20-25

The information and images, and equipment presented in this brochure are either standard or optional depending on the configuration. HIDROMEK has the right to modify the specifications and the designs of the model indicated in this brochure without prior notice.



More work within less time

8 % More productive*

Shortening the work cycle time with bigger bucket capacity and speed, H4 Series carry the productivity to the top level with their new technology.

8 % Faster*

With faster hydraulic movements due to developed hydraulic system design, H4 Series excavators ensure more work within less time.

* The data are prepared in comparison with the previous serie in HP mode.





HIDROMEK

210

HMK210W



More durable

Produced to have reinforced heavy duty construction considering maximum performance, long life and smooth operation in severe field conditions, HİDROMEK excavators ensure more durability with the improvements made in the new H4 Series.

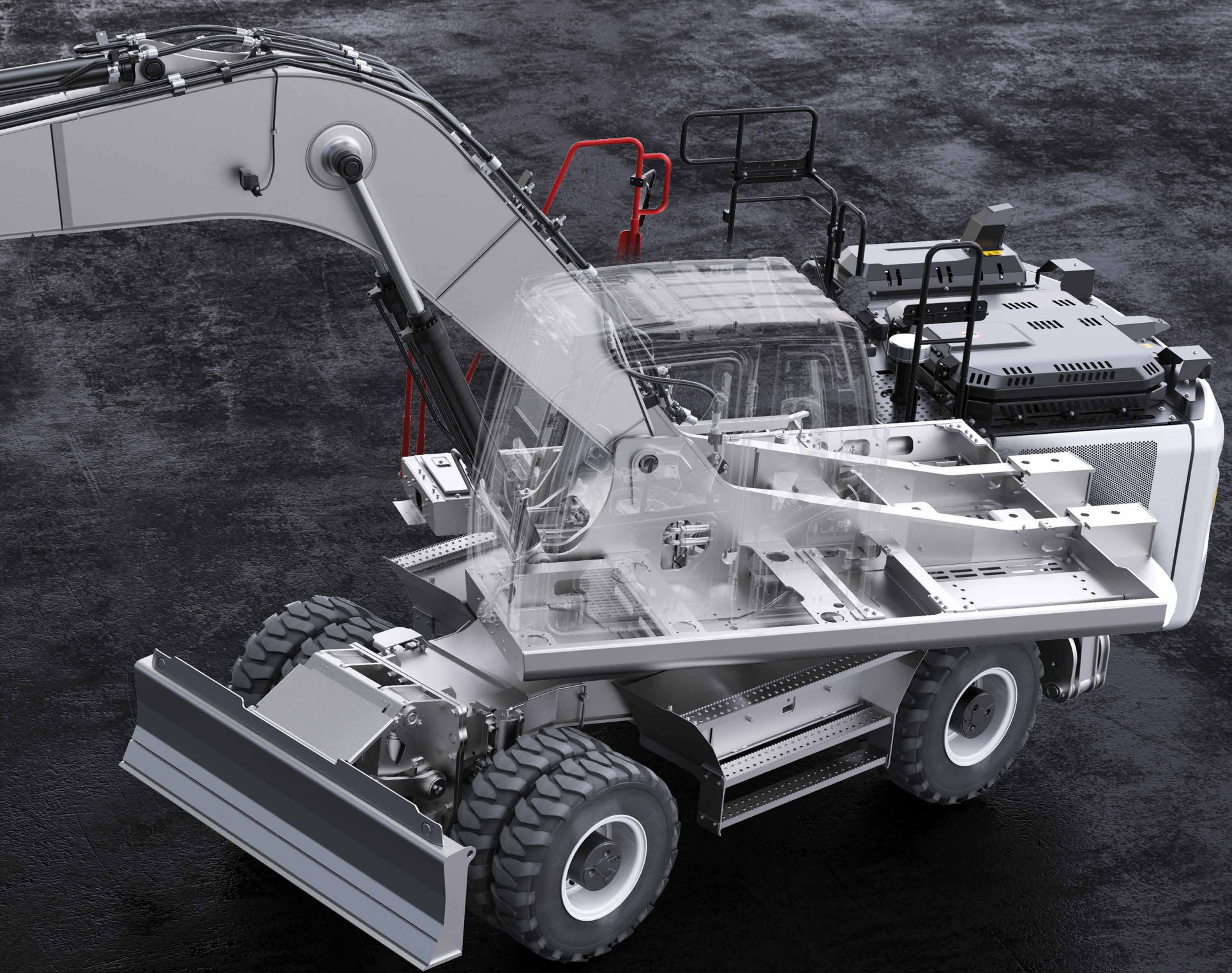

Reinforced heavy duty construction

With their reinforced heavy duty construction produced at HIDROMEK's modern production facilities and going through sensitive quality-control processes, H4 Series excavators have excellent durability.

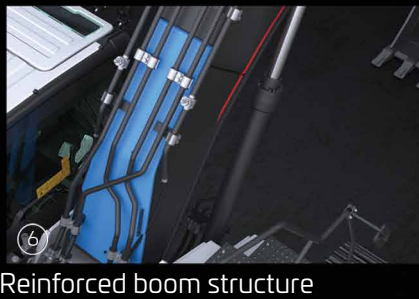
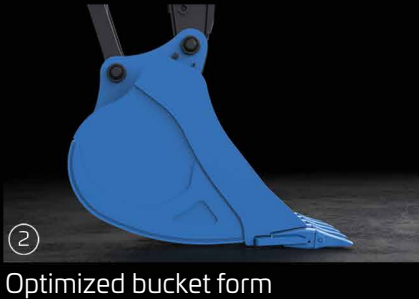

Bronze-Graphite Bushings



Bronze-graphite bushings used in boom-arm and boom-frame connection points increase the lubrication period, and greatly prevent the wear of the pins because of graphite, having a very high grease absorption and retention capability, embedded in the inner structure of the bushings.

④

①



HIDROMEK

210

HMK210W



7

6

3

2

Safeworkingenvironment

ROPS&FOPS cabin

Having the standards of ROPS (Roll Over Protective Structure) & FOPS (Falling Object Protective Structure), H4 Series excavators provide maximum safety and durability.

Wide vision capacity

Designed with giving special importance to occupational safety, H4 Series ensure excellent vision by minimizing the blind spot on the side and rear cameras. Along with the increase in the number of led headlights, the night vision is significantly improved on H4 Series excavators; in addition, there are also red handles and warning labels providing maximum safety for the operator.

Audio warning systems

H4 Series excavators enable safer working environment with their automatic starting horn, swing warning system and travel warning system.



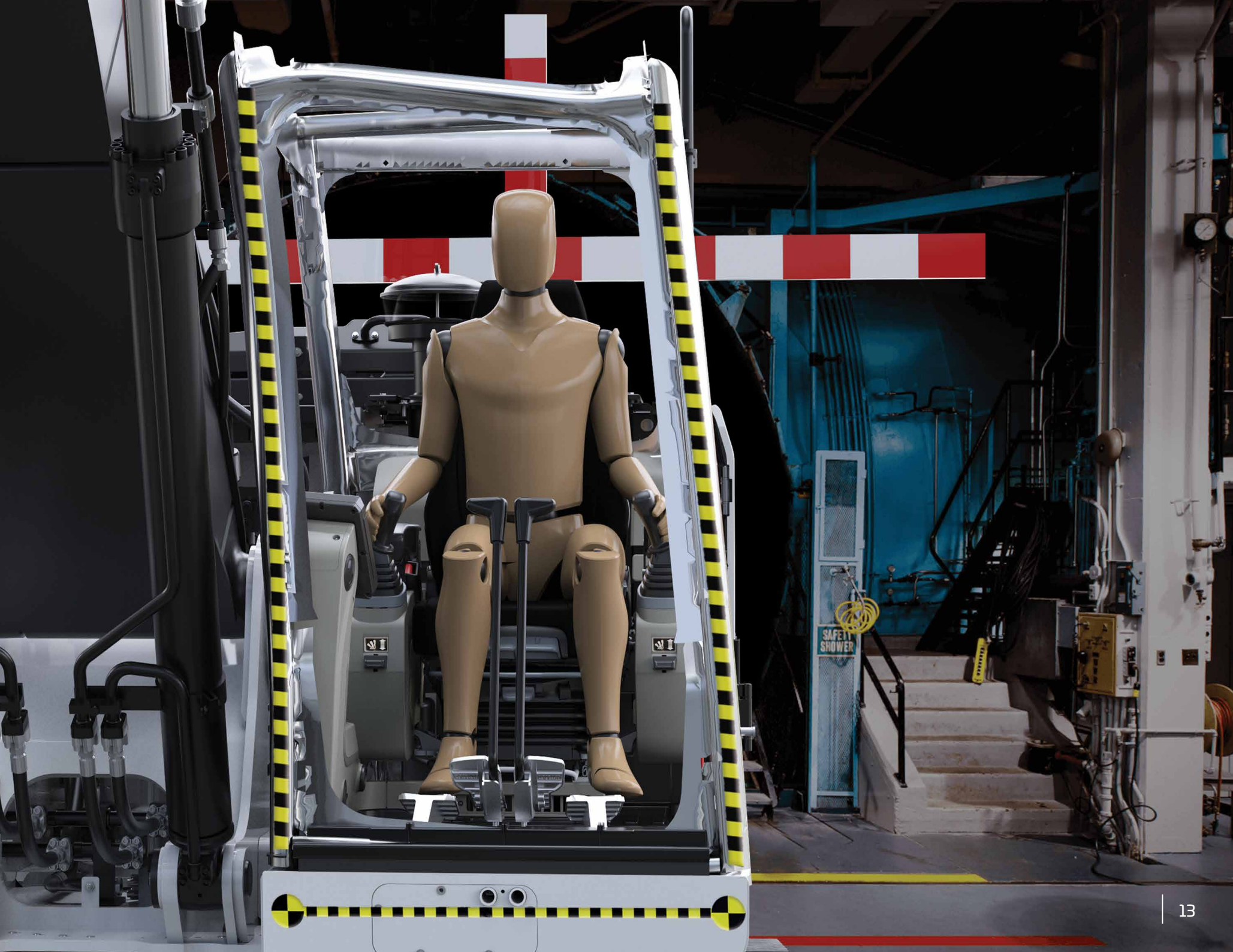

Shaped with technology

Electronic system of H4 Series excavators designed to protect the engine and hydraulic components to provide fuel saving and superior performance.

Automatic stop system

In the new series, automatic stop system through configurable idling and stopping times provides fuel saving by stopping the engine after the machine is on idle. Automatic stop system in H4 Series helps to decrease the operational costs to minimum, and contributes to saving the environment.

Safe fuel transfer pump

“Safe fuel transfer pump” added to H4 Series stops the pump automatically when the tank is full and this feature gets activated also when the pump does not transfer fuel for 30 seconds, and ensures that the pump stops automatically.

Power boost technology

In H4 Series, power boost technology gets activated automatically in the conditions when the machine needs extra power, and ensures that the machine has the proper performance for the work.

8” Touch control panel

8 inch touch control panel is positioned ergonomically at a point that the operator can easily reach it. Touch control panel having high quality hardware and a large screen easily enables to control the machine features and access to machine information.

The features of touch control panel:

- It offers multi-language option
- Music system is integrated into 8” touch control panel.
- It allows the operator to adjust the flow required for the attachment without leaving the cab and save this information for 20 different attachments.
- Selection of double or single acting line can also be done over the user panel.
- During travel, rear and side view cameras with improved image quality and activated automatically can be controlled.
- Information on the average and instant fuel consumption can be obtained.
- Information on status such as atmospheric pressure, turbo boost pressure, fuel pressure and hydraulic pump pressure can be obtained.
- User can acquire working hour information such as work, attachment and travel.
- Maintenance registries can be obtained, and the user is warned when the maintenance time approaches.
- Failure codes and registries can be obtained.
- Audio warning systems can be controlled.





OPERA, the guide of the field

H4 Series excavators are equipped with Opera (HIDROMEK Operator Interface) for the operator to use the machine easily, and feel comfortable and relaxed as he is in an office environment.

Functions to be controlled by means of Opera

- Engine RPM control
- Access to control panel menu
- Functions of lights, windshield wipers and rear view camera
- Music system control
- Auto stop control of the engine to ensure maximum fuel economy during low idle
- On H4 Series machines, the preheating system available to protect the engine and hydraulic systems can be controlled via Opera.

The aesthetic design of power

The seat ergonomic, heated, air suspended and having 35 degrees adjustable backrest angle is provided in H4 Series, and it enables the operator to work comfortably and without getting tired for long working hours.

H4 Series which has many features* such as proportional control pedals and joysticks, throttle control dial, operator touch screen, interior light, cup holder and heating-cooling box give more importance to user comfort.

HIDROMEK®

* Other features for user comfort on H4 Series machines can be found on page 21.

Office comfort in construction equipment

Automatic air conditioning system

Airvents and air conditioning system which can automatically adjust itself according to the ambient heat located in the redesigned cabin provide the best cooling performance in its class by 30%.

Wide angle view

On the new series machines, the new two-piece windshield wiper system designed for creating more comfortable work environment provides a wide angle view which increases the work efficiency of the user.

Led headlights for night vision

Led headlights on new H4 Series machines improve the night vision, and enable the operator to work more safely and comfortably.

Dampers

By using 6 silicone dampers on H4 Series excavators, noise, shock and vibration are absorbed and prevented from being transmitted to the cabin under any working condition.



You have the control with HÍDROMEK **SmartLink**

Telematic system HÍDROMEK Smartlink allows the user to easily access to machine location and technical information via computer and mobile phone.

Follow the work time and location of your machine through HÍDROMEK Smartlink!

Through GPS tracking system, it is possible to track the location and the work time intervals of the machine.

Analyze your fuel consumption through HÍDROMEK Smartlink!

It is possible to analyze fuel consumption according to the working conditions of the machine and daily fuel parameters.

Check the works for which your machine has been used through HÍDROMEK Smartlink!

Through working mode information, it is possible to see the daily and total working hours of the machine for excavation and leveling and with crusher or with other optional attachments besides the power mode information and the speed ranges.

Follow your machine's maintenance through HÍDROMEK Smartlink!

Under the Alerts list, the machine's upcoming maintenance can be checked while the information of the nearest authorized service can be obtained, and it can be contacted.

Contact the nearest authorized service or regional service through HÍDROMEK Smartlink!

With the application, it is possible to obtain the information on Regional and Authorized Services of HÍDROMEK After Sales Services as well as the directions to them.

Have performance reports for the selected periods of time for your machines through HÍDROMEK Smartlink!

For any selected periods of time, it is possible to have a report on daily fuel consumption, average fuel consumption, power and working modes, daily work time intervals and locations.



To download Smartlink application





Easy maintenance and fast service for H4 Series through safe and easy access

H4 Series excavators, designed considering fast access to hydraulic and engine equipment, provide easy maintenance and service. Most of the maintenance can be easily carried out without getting on the machine, which shortens the service time and increases machine work time.

Automatic greasing system ensures that all parts of the machine can be lubricated from one single center.



ENGINE

Brand & Model	ISUZU AI-4HK1X		
Type	Water cooled, 4 cycles, 4 cylinders, inline, diesel engine with direct injection, turbocharger and intercooler		
Power	Gross	172 HP (128 kW) @2000 rpm / SAE J1995	
	Net	162 HP (121 kW) @2000 rpm / SAE J1349	
Maximum Torque	Gross	677 Nm @1500 rpm	
	Net	656 Nm @1500 rpm	
Displacement	5193 cc		
Bore x Stroke	115 mm x 125 mm		
Emission Class	Stage IIIA / Tier 3 (EU/EPA)		

HYDRAULIC SYSTEM

MAIN PUMP

Type	2 axial piston pumps with variable displacement and swashplate
Max. Flow Rate	2 x 233 L/min
Pilot Pump	Gear type 20,5 L/min

WORKING PRESSURE

Attachment	350 kgf/cm ²
Power Boost	370 kgf/cm ²
Travel	370 kgf/cm ²
Swing	306 kgf/cm ²
Pilot	40 kgf/cm ²

HYDRAULIC CYLINDERS

Boom	2x ø120 x ø85 x 1300 mm
Arm	1x ø135 x ø95 x 1520 mm
Bucket	1x ø120 x ø85 x 1060 mm

SWING SYSTEM

Swing motor	Fixed swashplate piston motor integrated with super shock absorber valve
Reduction	2 stage, planetary gear type
Swing Brake	Hydraulic disc type, pilot operated and automatically released
Swing Speed	11,90 rpm

LOWER STRUCTURE (CHASSIS)

Chassis	Box shaped, reinforced lower chassis, front dozer blade and rear outriggers (stabilizers) as standard figures.
Axles	The pivot pin mounted front axle allows two options: 8° in each direction for best matching conditions, or could be locked at any desired position for perfect stability.
Tires	11,00 - 20 (16 Pr)

ELECTRICAL SYSTEM

Voltage	24 V
Battery	2 x 12 V / 100 Ah
Alternator	24 V / 50 A
Starter Motor	24 V / 5 kW

TRAVEL AND BRAKES

Travel	Fully hydrostatic	
Travel Motor	Piston motor with variable displacement.	
Reduction	Planetary gear system with 2 stages	
Travel Speed	High Speed	31 km/h
	Low Speed	7,5 km/h
Max. Traction	11.120 kgf	
Gradeability	29° (%56)	
Parking Brake	Hydraulic, disc type with automatic warning	
Service Brake	Fully hydraulically operating disc type brakes with spring return, independent for front and rear axles.	

FILLING CAPACITIES

Fuel Tank	345 L	Engine Cooling System	33 L
Hydraulic Tank	160 L	Engine Oil	21 L
Hydraulic System	318 L		

OPERATING WEIGHT (kg)

	Mono Boom	Two Pieces Boom
HMK 210 W	22.350	22.950

EQUIPMENT

HMK 210 W

Engine	Standard	Optional
Water cooled diesel engine with turbocharger and intercooler	●	
Engine pre-heat function	●	
Automatic idling	●	
One touch auto-idle system	●	
Automatic stop function	●	
Two-stage air filter	●	
Air filter clogged indicator	●	
Low engine pressure warning system	●	
Overheat warning system	●	
Adjustable power modes	●	
High altitude working function	●	
Electronical engine control	●	

Hydraulic System	Standard	Optional
Boom and arm regeneration valve	●	
Automatic power boost	●	
Smooth boom feature		0
Main hydraulic filter	●	
Backup ports (valve)	●	
Cylinder cushioning and contamination seals	●	
Single-acting hydraulic line, breaker		0
Double- acting hydraulic line, crusher		0
Additional line		0
Quick coupling line		0
Attachment settings through instrument panel		0

OPERATOR'S CAB	Standard	Optional
Pressurized and sound isolated cabin	●	
Air-conditioning	●	
Air-suspension seat	●	
Heated seat		0
Operator touch screen	●	
Opera control system	●	
Throttle control dial	●	
Automatic travel speed (low / high)	●	
4 different working modes	●	
Sliding windscreen and removable lower windscreen	●	
Openable left door window	●	
Upper and lower windshield wiper	●	
Joysticks and pedals	●	
Travel pedals and control levers	●	
Proportional controlled pedals and joysticks		0
Electric horn	●	
Intrerior light	●	
Cup-holder	●	
Convenient storage	●	
Convenient storage (for equipment)	●	
Heating & Cooling box	●	
Easy-cleaned floor	●	
12V power socket	●	
Computer connection port	●	
Radio / mp3 / usb / Aux	●	

Safety	Standard	Optional
ROPS (Roll Over Protective Structure)	●	
FOPS (Falling Object Protective Structure)	●	
Rear view camera	●	
Side view camera		0
Right and left rear view mirrors	●	
Working lamps	●	
LED working lamps		0
Rotating beacon		0
Swing and travel alarm		0
Emergency engine stop switch	●	
Pilot operated and automatically released swing brake	●	
Boom and arm cylinder safety valve		0
Overload warning system		0
Battery cut-off switch	●	
Handrails by the steps and on the upper frame	●	
Perforated metal non-slip plates	●	
Safety locking device	●	
Safety glass	●	
Emergency hammer	●	
Lockable fuel tank cover	●	
Upper and lower guards for windshield		0
Operator's cab ceiling guard		0

Miscellaneous	Standard	Optional
Telematic system (HIDROMEK Smartlink)		0
GEO System		0
Fuel transfer pump with automatic stop	●	
Water sensor on fuel pre-filter	●	
Bio oil B7	●	
Alternator - Battery	●	
Battery Charge Indicator	●	
Automatic lubrication system		0
Working lamp guards		0
Hydraulic breaker return line filter		0
Double pump combination function		0
Choosing single or double acting attachment on the instrument panel		0
Choosing the control method for the optional attachment		0
Boom cylinder piping guard		0
Bucket cylinder rod guard		0
Warning horn	●	
Counterweights		0

● STANDARD 0 OPTIONAL

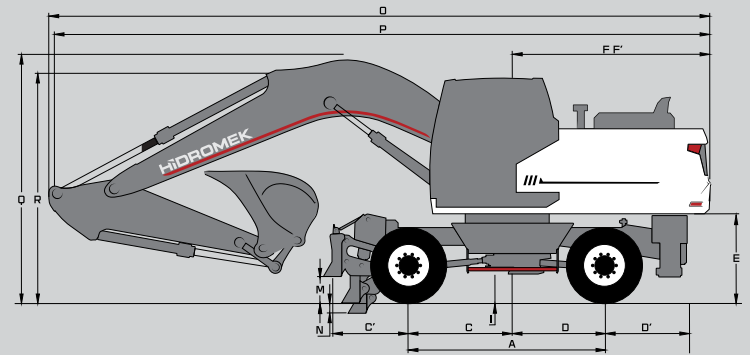
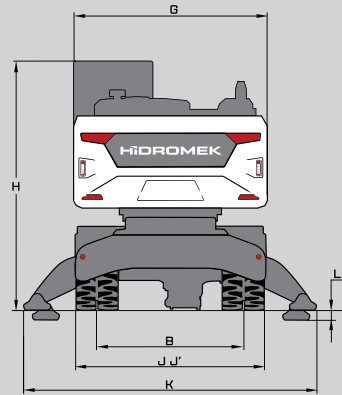
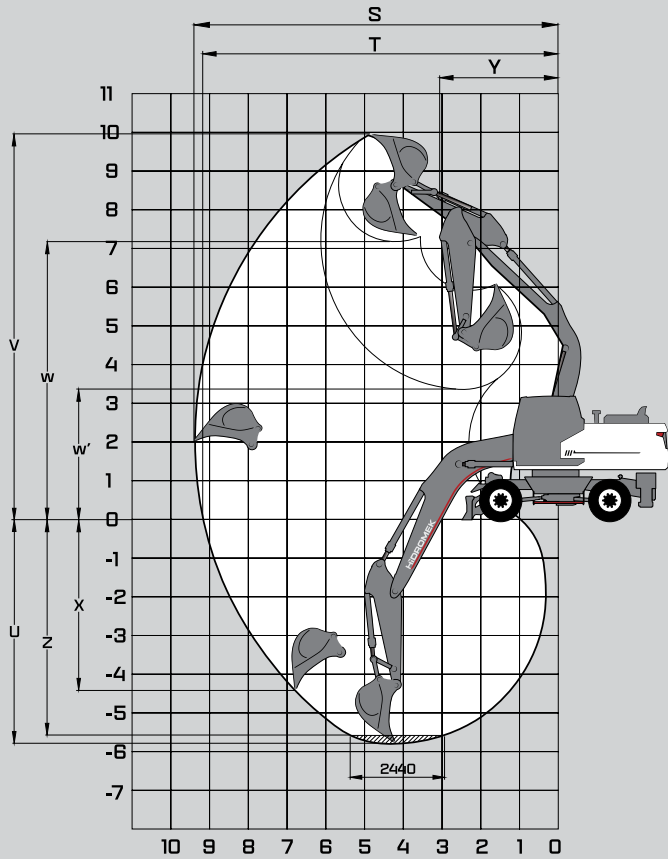

DIMENSIONS

		Mono Boom		Two Pieces Boom	
BOM (m)		*5,60		5,50	
ARM (m)		*2,40	2,92	2,40	2,92
GENERAL DIMENSIONS (mm)	A) Axle Distance	2.850			
	B) Track Gauge	1.914			
	C) Swing-centre to Front Axle	1.500			
	C') Front overhang	1.242			
	D) Swing-centre to Rear Axle	1.350			
	D') Rear overhang	1.153			
	E) Counterweight clearance	1.294			
	F) Distance from center of swing to rear end	2.855			
	F') Tail Swing Radius	2.885			
	G) Overall Width of upperstructure	2.500			
	H) Overall height of cab	3.220			
	I) Minimum Ground Clearance, Outrigger	348			
	I') Minimum Ground Clearance	384			
	J) Overall Width tires	2.540			
	J') Overall width of Outrigger retract	2.550			
	K) Overall Width Outrigger extend	3.791			
	L) Max. Outrigger lower	117			
	M) Dozer Blade Ground Clearance	353			
N) Max. Dozer Blade Lower	123				
WORKING RANGES (mm)	O) Overall Length / Travel	9.590	9.610	8.385	8.765
	P) Overall Length/ Transport	9.480	9.550	9.510	9.520
	Q) Boom Height / Travel	3.610	3.690	3.985	3.925
	R) Boom Height / Transport	3.330	3.450	3.185	3.220
	S) Maximum Digging Reach	9.400	9.790	9.460	9.910
	T) Maximum Digging Reach at Ground Level	9.170	9.570	9.240	9.700
	U) Maximum Digging Depth	5.770	6.290	5.740	6.240
	V) Maximum Digging Height	9.960	10.020	10.360	10.560
	W) Maximum Dumping Height	7.170	7.280	7.460	7.690
	W') Minimum Dumping Height	3.360	2.840	3.360	2.800
	X) Maximum Vertical Digging Depth	4.430	4.620	4.630	5.000
	Y) Minimum Swing Radius	3.080	3.050	3.230	3.130
Z) Maximum Digging Depth (2440 mm level)	5.560	6.100	5.640	6.150	

* Standard

FORCES

		Mono Boom		Two Pieces Boom	
BOM (m)		*5,60		5,50	
ARM (m)		*2,40	2,92	2,40	2,92
SAE	Bucket Digging Force	13.300			
	Bucket Digging Force (Power Boost)	14.000			
	Arm Crowd Force	11.400	10.000	11.400	10.000
	Arm Crowd Force (Power Boost)	12.100	10.600	12.100	10.600
ISO	Bucket Digging Force	14.900			
	Bucket Digging Force (Power Boost)	15.800			
	Arm Crowd Force	11.800	10.400	11.800	10.400
	Arm Crowd Force (Power Boost)	12.500	10.900	12.500	10.900

A- Material density less than 2.000 kg/m³
 B- Material density less than 1.800 kg/m³
 C- Material density less than 1.500 kg/m³
 D- Material density less than 1.200 kg/m³

* Standard

STANDARD BUCKET



Width	1.110 mm	
Capacity (SAE)	*0,9 m ³	
Weight	750 kg	
Number of Teeth	4	
ARM	*2,40 m	A
	2,92 m	A

OPTIONAL BUCKET SELECTION SCHEME

General Purpose Bucket



Dual Radius Type Bucket



600 mm	750 mm	900 mm	1050 mm	1200 mm	1400 mm	600 mm	750 mm	900 mm	1030 mm	1200 mm	1290 mm	1370 mm
0,41 m ³	0,54 m ³	0,69 m ³	0,84 m ³	1,00 m ³	1,20 m ³	0,40 m ³	0,52 m ³	0,67 m ³	0,82 m ³	1,00 m ³	1,10 m ³	1,20 m ³
510 kg	580 kg	650 kg	700 kg	780 kg	950 kg	510 kg	600 kg	670 kg	720 kg	820 kg	860 kg	880 kg
3	3	4	4	5	5	3	3	4	4	5	5	5
A	A	A	A	A	A	A	A	A	A	A	A	A
A	A	A	A	A	A	A	A	A	A	A	A	A

* Standard

QUICK COUPLER



SIEVE BUCKET

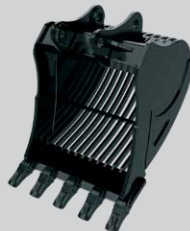

ROCK TYPE BUCKET



POLYP



RIPPER



CLEANING BUCKET



HEAVY DUTY

ATTACHMENTS

LIFTING CAPACITY (kg)											HMK 210 W		
	Boom: 5,6 m		Arm: 2,4 m		Without bucket		Front Outrigger/Rear Outrigger		D.A: 3800 kg		📏 : Front 📏 : Side		
A, m	1,5		3,0		4,5		6,0		7,5		Maximum Reach		
B, m	📏	📏	📏	📏	📏	📏	📏	📏	📏	📏	📏	📏	R, m
7,5											*5250	*5250	5,67
6,0					*5200	*5200	*5100	*5100			*5200	5100	6,83
4,5			*9300	*9300	*6550	*6550	*5600	*5600	*5350	4300	*5300	4300	7,52
3,0					*8500	*8500	*6450	5900	*5600	4200	*5450	3900	7,87
1,5					*10050	8550	*7300	5650	*6000	4100	*5800	3800	7,91
0 (Ground)					*10750	8300	*7800	5450	*6250	4000	*6100	3900	7,65
-1,5			*13600	*13600	*10700	8300	*7900	5400			*6500	4350	7,07
-3,0			*13800	*13800	*9750	8400	*7050	5550			*6900	5450	6,06

LIFTING CAPACITY (kg)											HMK 210 W		
	Boom: 5,6 m		Arm: 2,92 m		Without bucket		Front Outrigger/Rear Outrigger		D.A: 3800 kg		📏 : Front 📏 : Side		
A, m	1,5		3,0		4,5		6,0		7,5		Maximum Reach		
B, m	📏	📏	📏	📏	📏	📏	📏	📏	📏	📏	📏	📏	R, m
7,5							*4550	*4550			*4400	*4400	6,21
6,0							*4500	*4500			*4200	*4200	7,29
4,5					*5750	*5750	*5100	*5100	*4850	4350	*4150	3950	7,93
3,0					*7700	*7700	*6000	5950	*5250	4200	*4350	3600	8,26
1,5					*9450	8600	*6900	5600	*5700	4050	*4700	3500	8,30
0 (Ground)			*8100	*8100	*10450	8250	*7550	5400	*6050	3950	*5400	3550	8,06
-1,5	*8600	*8600	*13200	*13200	*10650	8150	*7800	5300	*6100	3900	*6100	3900	7,50
-3,0	*13750	*13750	*14700	*14700	*10100	8250	*7400	5350			*6600	4750	6,57
-4,5			*11800	*11800	*8200	*8200					*7150	*7150	5,01

LIFTING CAPACITY (kg)											HMK210 W 2P		
	Boom: 5,5 m		Arm: 2,4 m		Without bucket		Front Outrigger/Rear Outrigger		D.A: 3800 kg		📍 : Front 📍 : Side		
A, m	1,5		3,0		4,5		6,0		7,5		Maximum Reach		
B, m	📍	📍	📍	📍	📍	📍	📍	📍	📍	📍	📍	R, m	
7,5											*5050	*5050	5,76
6,0					*4450	*4450	*4700	*4700			*5150	5050	6,91
4,5					*5850	*5850	*5250	*5250	*5300	4350	*5300	4250	7,59
3,0					*8000	*8000	*6200	5950	*5600	4250	*5300	3900	7,93
1,5					*10050	8650	*7300	5700	*6200	4150	*5550	3800	7,97
0 (Ground)					*11350	8450	*8150	5550	*6750	4050	*6050	3950	7,72
-1,5			*11750	*11750	*11900	8450	*8700	5500			*7000	4400	7,14
-3,0													

LIFTING CAPACITY (kg)											HMK210 W 2P		
	Boom: 5,5 m		Arm: 2,92 m		Without bucket		Front Outrigger/Rear Outrigger		D.A: 3800 kg		📍 : Front 📍 : Side		
A, m	1,5		3,0		4,5		6,0		7,5		Maximum Reach		
B, m	📍	📍	📍	📍	📍	📍	📍	📍	📍	📍	📍	R, m	
9,0					*4250	*4250					*4400	*4400	4,61
7,5							*4150	*4150			*4450	*4450	6,37
6,0							*4050	*4050			*4300	*4300	7,42
4,5					*5000	*5000	*4650	*4650	*4650	4400	*4150	3850	8,06
3,0					*7100	*7100	*5650	*5650	*5150	4250	*4200	3550	8,38
1,5					*9250	8750	*6800	5700	*5750	4100	*4400	3450	8,42
0 (Ground)			*6300	*6300	*10800	8400	*7800	5500	*6400	4000	*4800	3550	8,18
-1,5			*11600	*11600	*11650	8300	*8450	5400	*6800	4000	*5600	3900	7,64
-3,0					*11750	8400	*8600	5500					

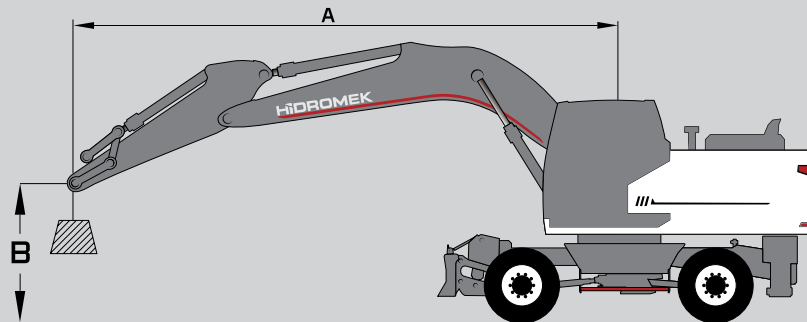

- A Load Radius
- B Load Point Height
- C Lifting Capacity

1. The above loads are in compliance with SAE J1097 and ISO 10567 Hydraulic Excavator Lifting Capacity Standards
2. The load point is the center-line of the bucket pivot mounting pin on the arm
3. Lifting capacity cannot exceed 75% of tipping capacity or 87% of hydraulic capacity.
4. (*) indicates load limited by hydraulic capacity.

HIDROMEK®

HEAD OFFICE

Address: Ahi Evran OSB Mahallesi,
Osmanlı Caddesi, No:1, 06935
Sincan-ANKARA/TURKEY

Phone : +90 312 267 12 60

Fax : +90 312 267 12 39

E-mail: export@hidromek.com.tr

AFTER SALES SERVICE

Address: İstanbul Yolu 17. Km,
Şehit Osman Avcı Mahallesi,
No: 479, Etimesgut-ANKARA/TURKEY

Phone : +90 312 280 87 40

Fax : +90 312 280 87 48

HIDROMEK® WEST

HIDROMEK MAQUINARIA DE CONSTRUCCION ESPAÑA S.L.

Address: Avenida Del Progres 7 08840 –
Viladecans Barcelona/ SPAIN

Phone : +34 93 638 84 65

E-mail : info@hidromek.es

HIDROMEK® JAPAN

Address: 5-10, Hashimoto 6-chome,
Midori-Ku, Sagamihara,
Kanagawa, 252-0143 JAPAN

Phone : +81 42 703 0261

Fax : +81 42 703 0262

HIDROMEK® RUS

Address: 72, Zhivopisnaya str, Building A,
village Oktyabrskiy,
Krasnodar, 350032, RUSSIA

Phone : +7 861 290 3007

E-mail : info@hidromek.ru

HIDROMEK® HCE

HIDROMEK Construction Equipment (Thailand) Ltd.

Address: Amata City Chonburi Industrial Estate Phase 7,
No. 700/669 Moo 1, T.Phanthong,
A.Phanthong, Chonburi 20160, TAYLAND

Phone : +66 38 447 349

Fax : +66 38 447 355

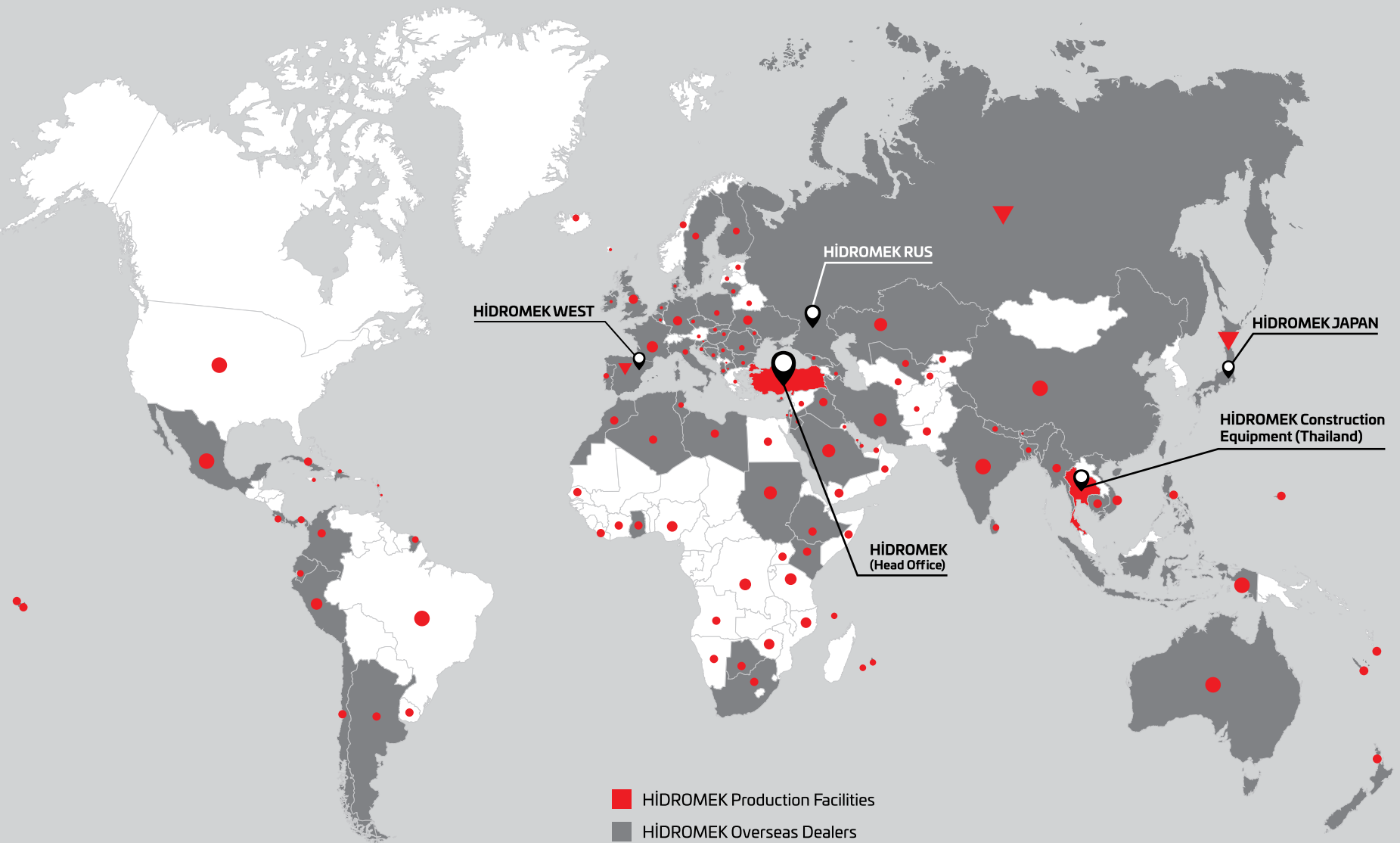

HIDROMEK®

Together Stronger

www.hidromek.com

[f hidromek.tr](https://www.facebook.com/hidromek.tr) [t Hidromek](https://twitter.com/Hidromek) [i hidromekofficial](https://www.instagram.com/hidromekofficial) [y HidromekTv](https://www.youtube.com/HidromekTv) [in company/hidromek](https://www.linkedin.com/company/hidromek)

